

PROJETO 3D - 330 LTS SEXTO VIDRO



CLIENTE: JEFERSON STUTZ

CRIAÇÃO SEXTO VIDRO

João Carlos
BASSO

ADAPTAÇÃO DO PROJETO



DIVULGAÇÃO



REEFTECH

EXECUÇÃO



João Carlos BASSO

ADAPTAÇÃO DO PROJETO



DIVULGAÇÃO



REEFTECH

EXECUÇÃO

aquarioX

AQUÁRIO JEFFERSON STUTZ

- *MODELO SEXTO VIDRO PADRÃO AVIV ADAPTADO
- DESCIDA DE ÁGUA COM CAIXA EXTERNA.
- *VIDROS PADRÃO EXTRA CLEAR LAPIDADOS.
- *MÓVEL 3 PORTAS, ALTO PADRÃO COM ACRILICO NAS JANELAS, PRETO FOSCO LACA.
- *TUBULAÇÃO DESCIDA (VALVULA GAVETA 1"POL + SUBIDA 3/4"POL - MARCA TIGRE CPVC PRETO)
- *LOCK LINE INDUSTRIAL 3/4" PINTADO DE PRETO.
- *SUMP DE ACORDO COM EQUIPAMENTOS USADOS.
- *CAIXA SECA PERSONALIZADA PARA ELETRÔNICOS.

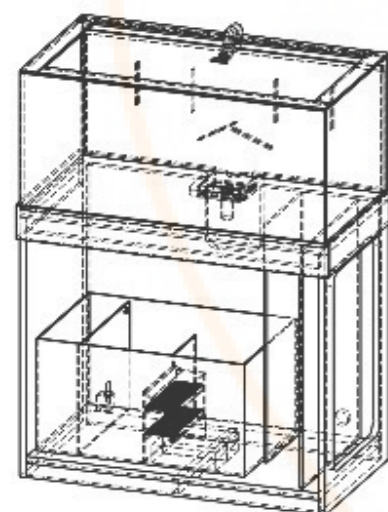
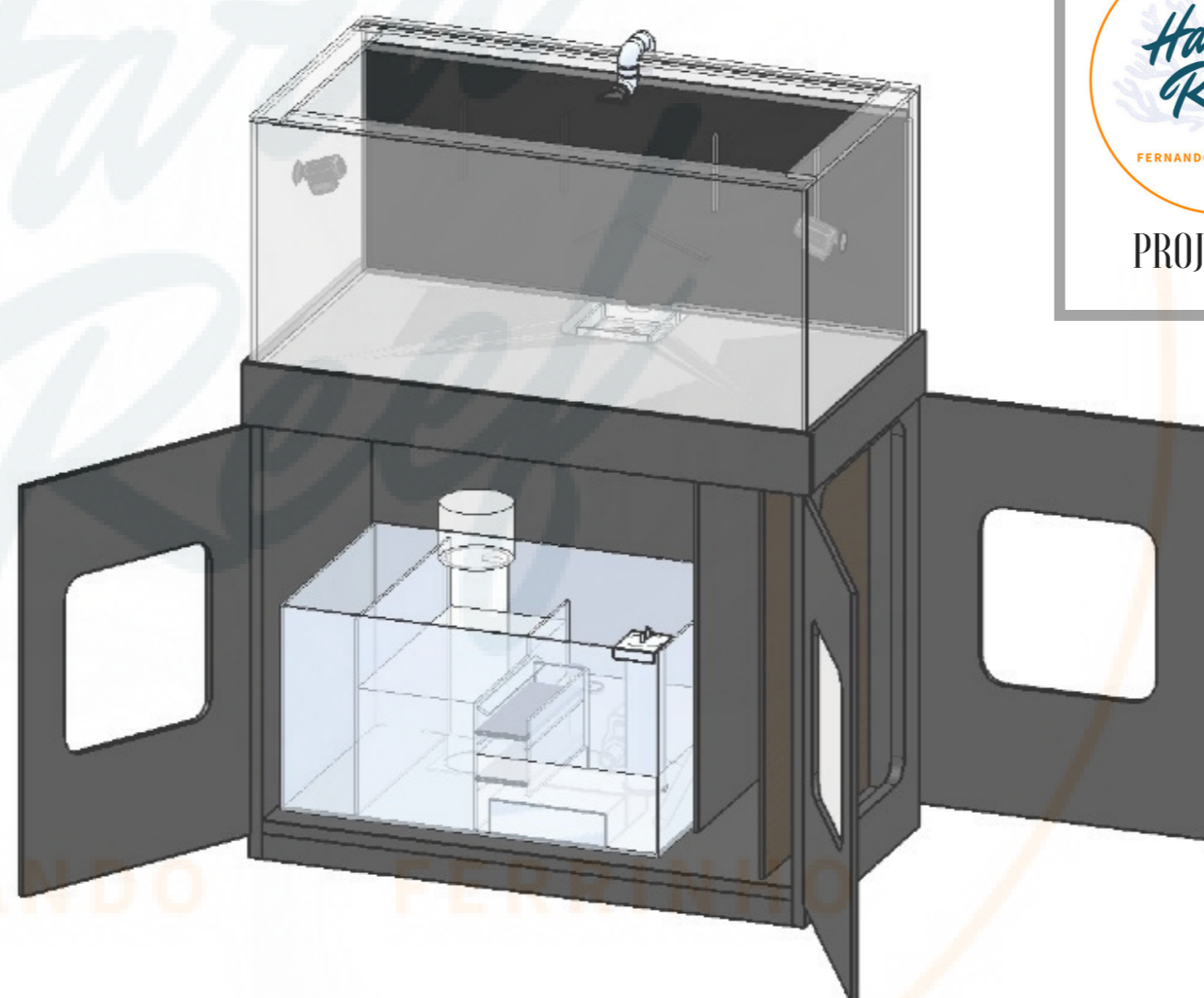
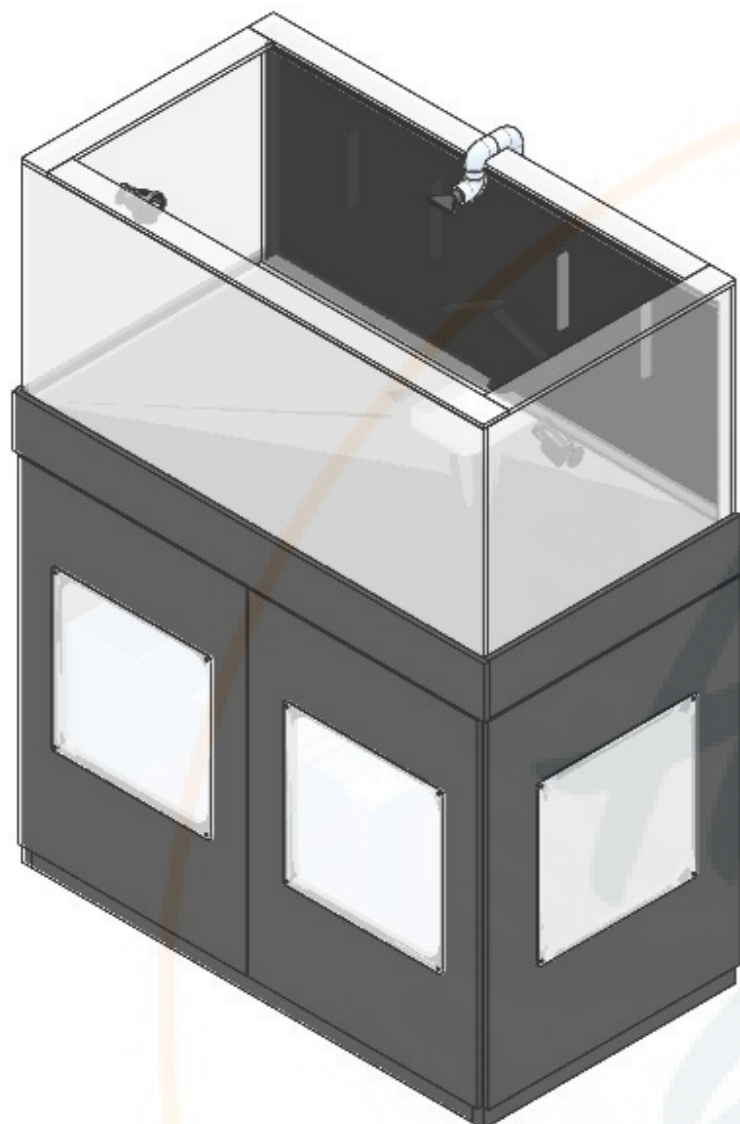
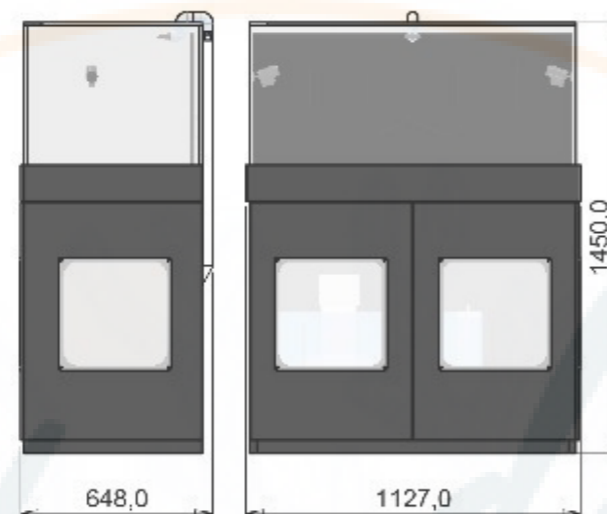

João Carlos BASSO

ADAPTAÇÃO DO PROJETO



DIVULGAÇÃO



REEFTECH

EXECUÇÃO



AQUARIO JEFERSON STUTZ
 *ACABAMENTO VIDROS LAPIDAÇÃO RETA
 *ESPESSURA MIN. DE 1MM DE SILICONE ENTRE VIDROS BASE (MAX.)
 *VIDROS LATERAIS E FRONTAL EXTRA CLEAR 10MM
 *VIDRO FUNDO 12MM
 *SEXTO VIDRO DUPLO SANDUICHE 5MM
 *VALVULA 1" - RECALQUE ATÉ 6000lts/h
 *PEÇAS BASE PODEM SER MONTADAS PRIMEIRO

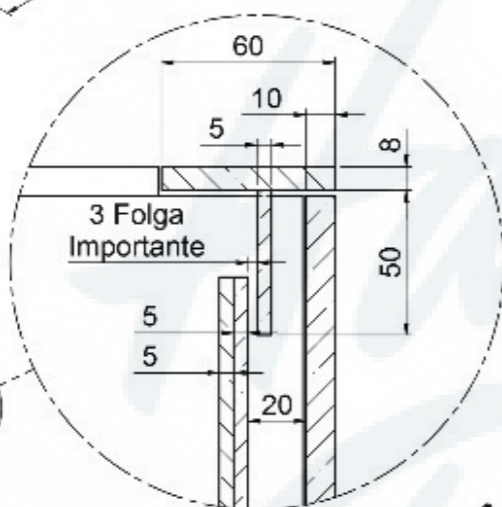
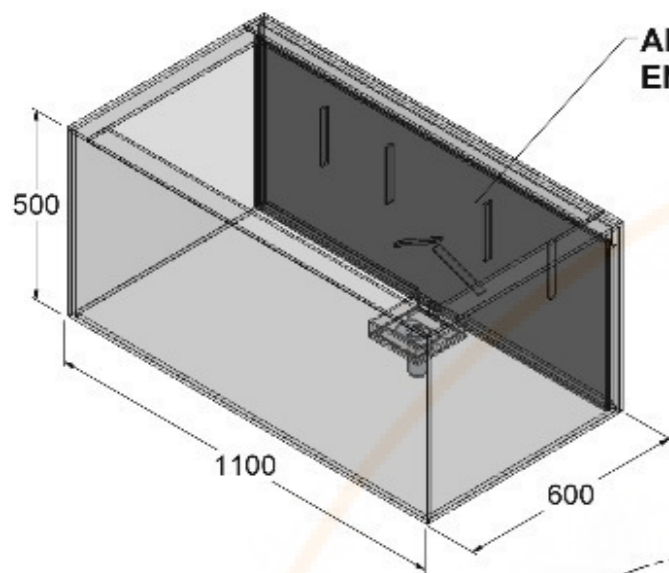

FURO MEIA CANA 50MM

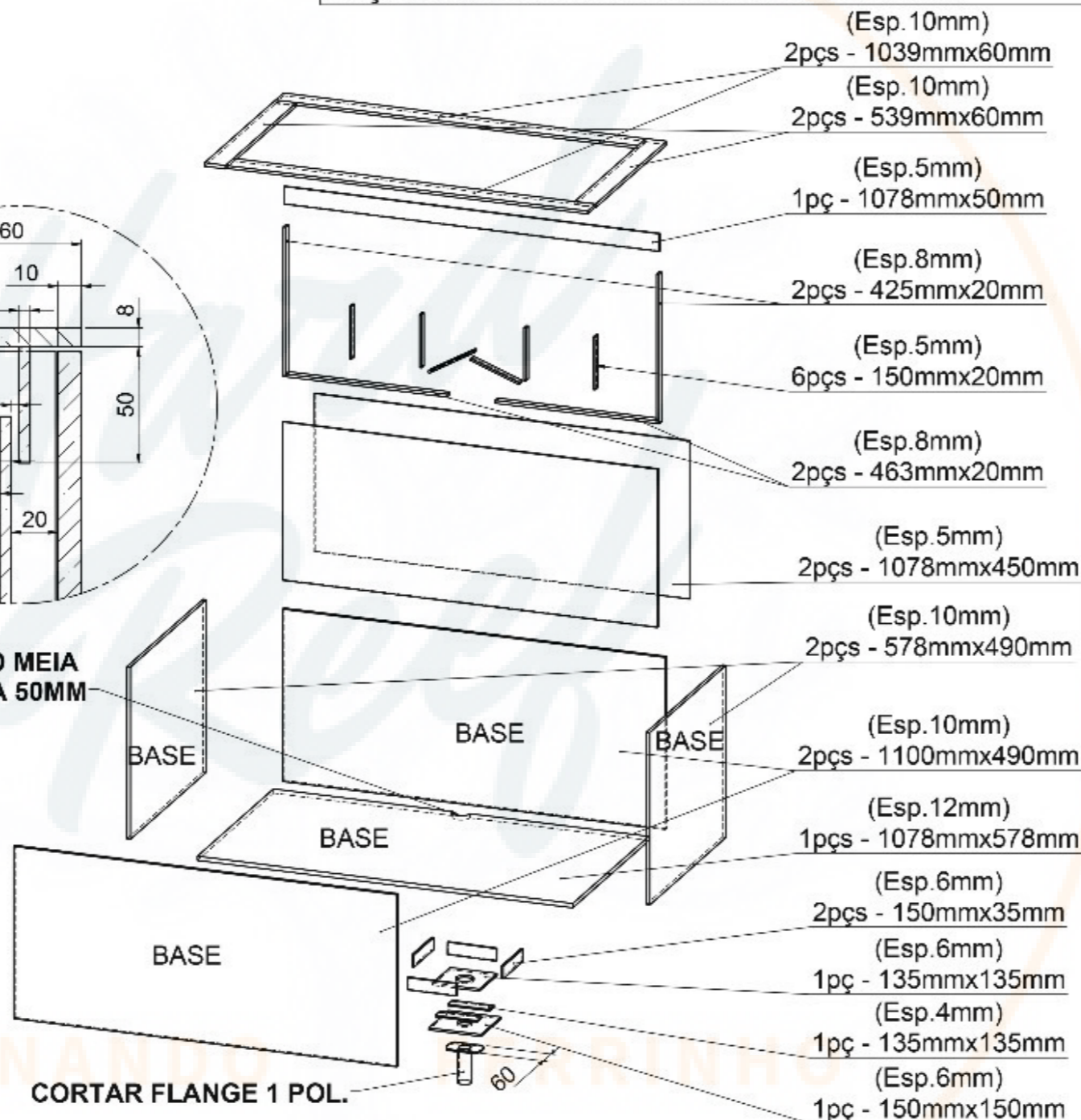
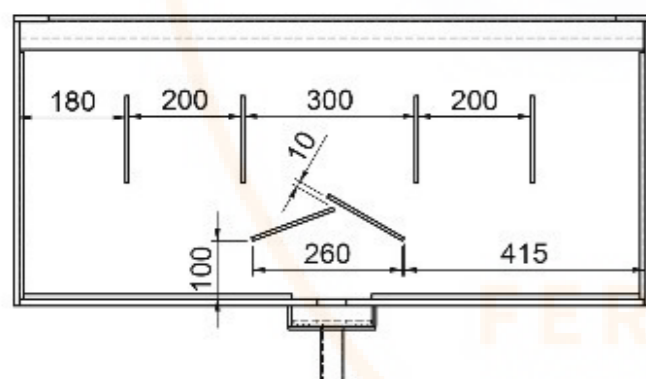
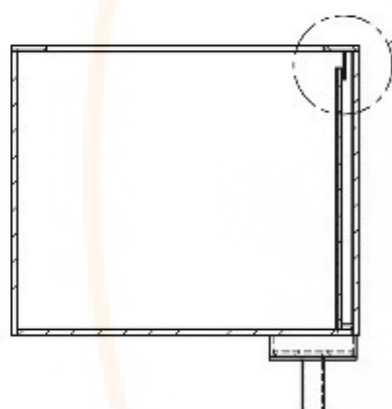

João Carlos BASSO

ADAPTAÇÃO DO PROJETO



DIVULGAÇÃO



REEFTECH

EXECUÇÃO



SUMP JEFFERSON STUTZ
*VIDROS 6MM ESPESSURA
*SILICONE PRETO
*DISPONIBILIZAR DUAS PLACAS DE COLMEIA PARA MÍDIAS CONFORME MEDIDAS.

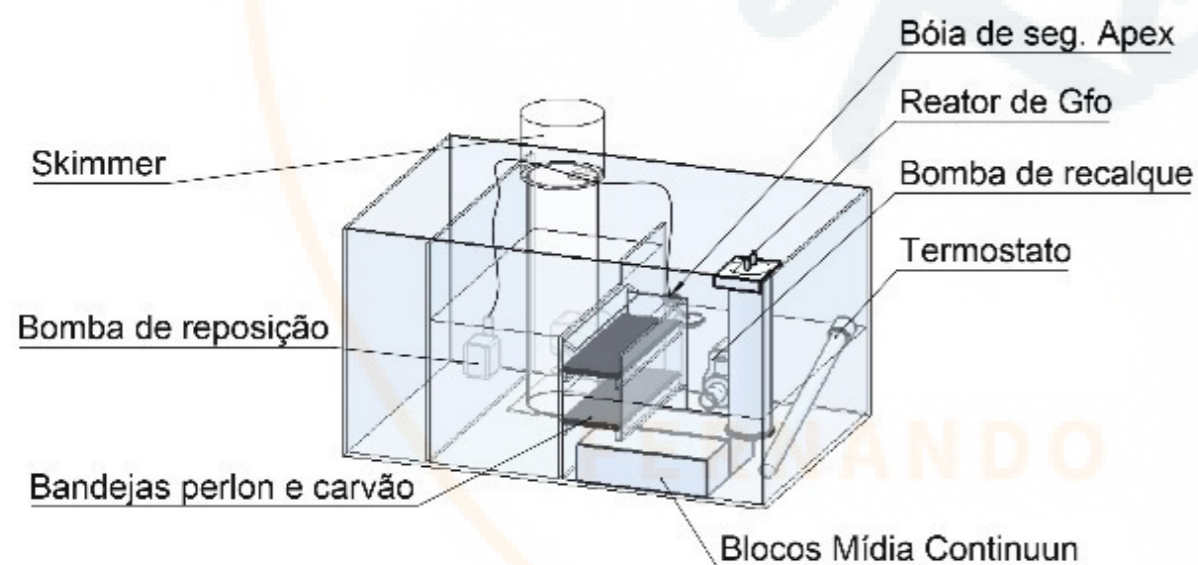
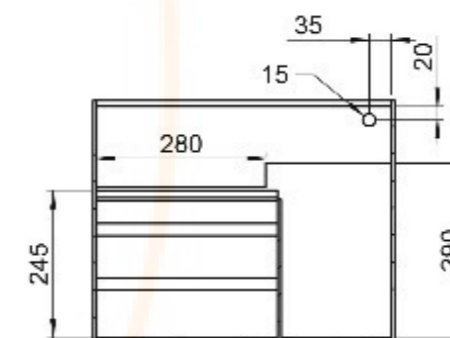
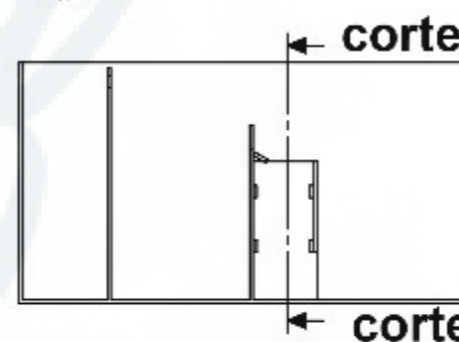
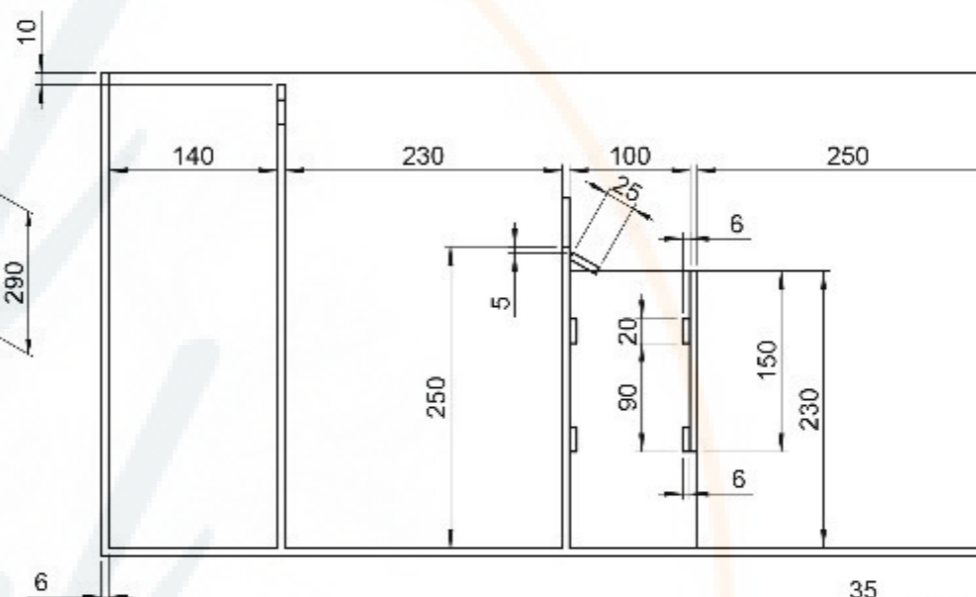
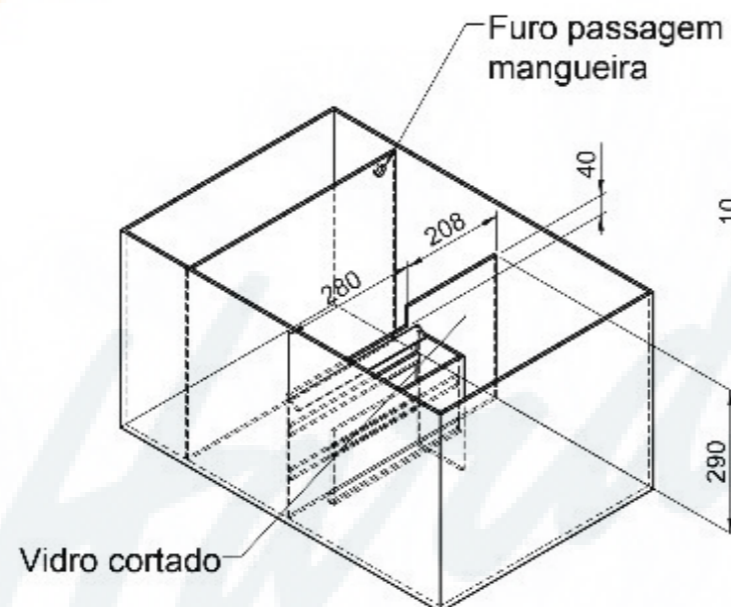
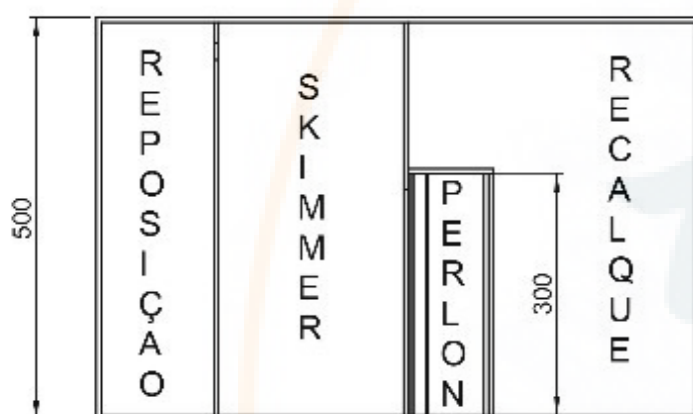
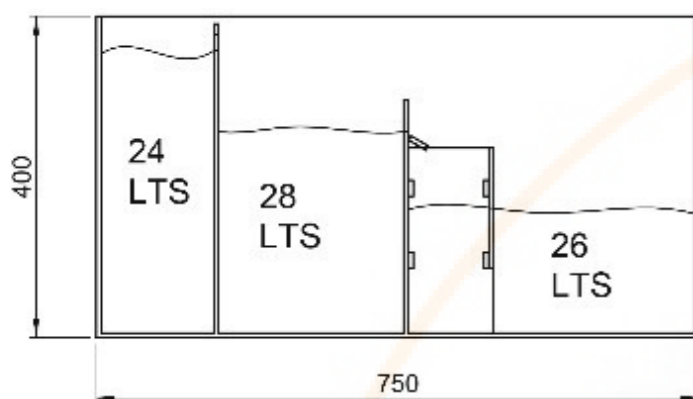

João Carlos BASSO

ADAPTAÇÃO DO PROJETO



DIVULGAÇÃO



REEFTECH

EXECUÇÃO



MÓVEL JEFERSON STUTZ
 * PEÇAS DE ESP. 25MM EM COMPENSADO NAVAL.
 * DEMAIS PEÇAS COMO ACABAMENTO E PORTAS PODEM SER MESMO MATERIAL OU MDF ULTRA.
 * LIXAR COM LIXA FINA E DAR BOM ACABAMENTO.
 * APLICAR PRIMER.
 * PINTURA EM LACA.
 * COR PRETO FOSCA.
 * INSTALAR DOBRADIÇAS DE INOX.

